

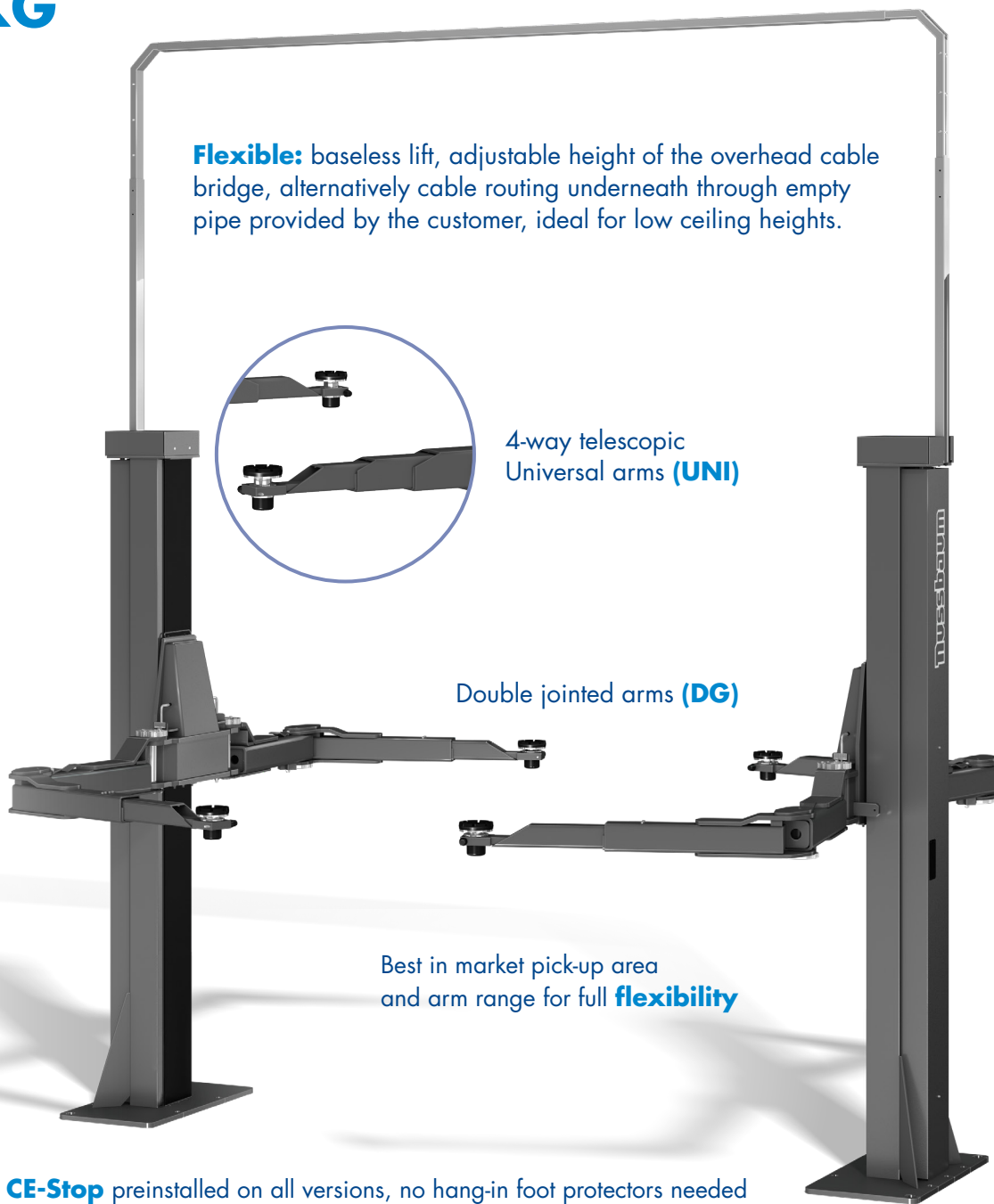

SMART LIFT 2.55 SL

5500 KG



Flexible: baseless lift, adjustable height of the overhead cable bridge, alternatively cable routing underneath through empty pipe provided by the customer, ideal for low ceiling heights.

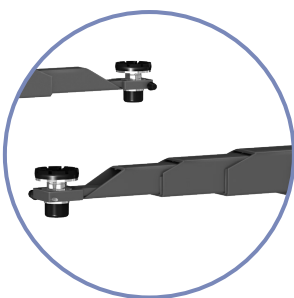

4-way telescopic Universal arms (UNI)

Double jointed arms (DG)

Best in market pick-up area and arm range for full flexibility

CE-Stop preinstalled on all versions, no hang-in foot protectors needed

THE ORIGINAL NUSSBAUM LIFT

- Flexible height : Ideal for workshops with low ceilings
- Double-jointed arms for a wide lifting capacity range (DG version)
- Low space requirement

The original among the (mechanical) 2-post lifts

SPACE-SAVING, FLEXIBLE, PERFECT FOR LOW CEILING HEIGHTS

Options:

- Energy set
- Second operation (retrofit not possible)
- Wheel forks, Mini-Max & adapters sets

UNI - Universal arm

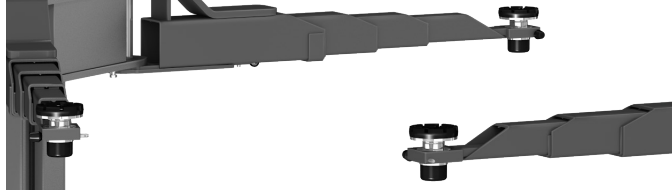

DG - Double joint arm

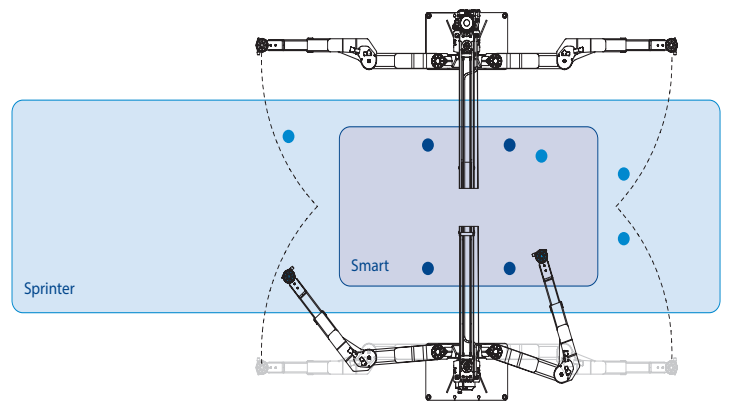
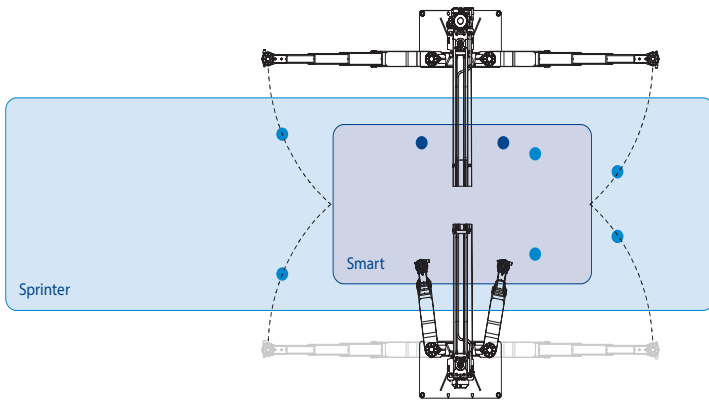
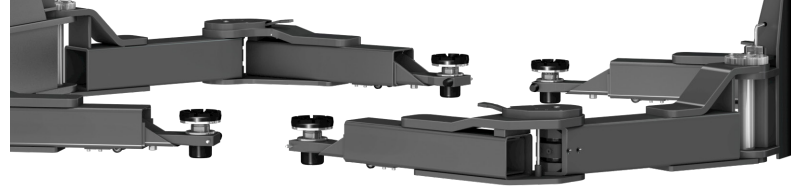

SMART LIFT 2.55 SL	UNI	DG
Lifting capacity (kg)	5500	5500
Lifting time approx. (sec)	48 / 40	48 / 40
Lifting height (mm)	2015	2014
Lowest lifting point (mm)	133-198	121-196
Arm-extraction (mm)	695-1700	max. 1833
Total height (mm)	4778	4778
Min. Drive-through width (mm)	2520	2520
Column distance (mm)	2850	2850
Recommended total width (mm)	3570	3570
Total width (mm)	3570	4370
Power supply (V/Hz/A)	400 / 50 / 16	400 / 50 / 16
Motor (kW)	2x1,5	2x1,5



Wheel-fork adapter



Height adapter round



Adapters for MERCEDES Sprinter



Height adapter U-form



Mini-Max adapter

Additional accessories available