

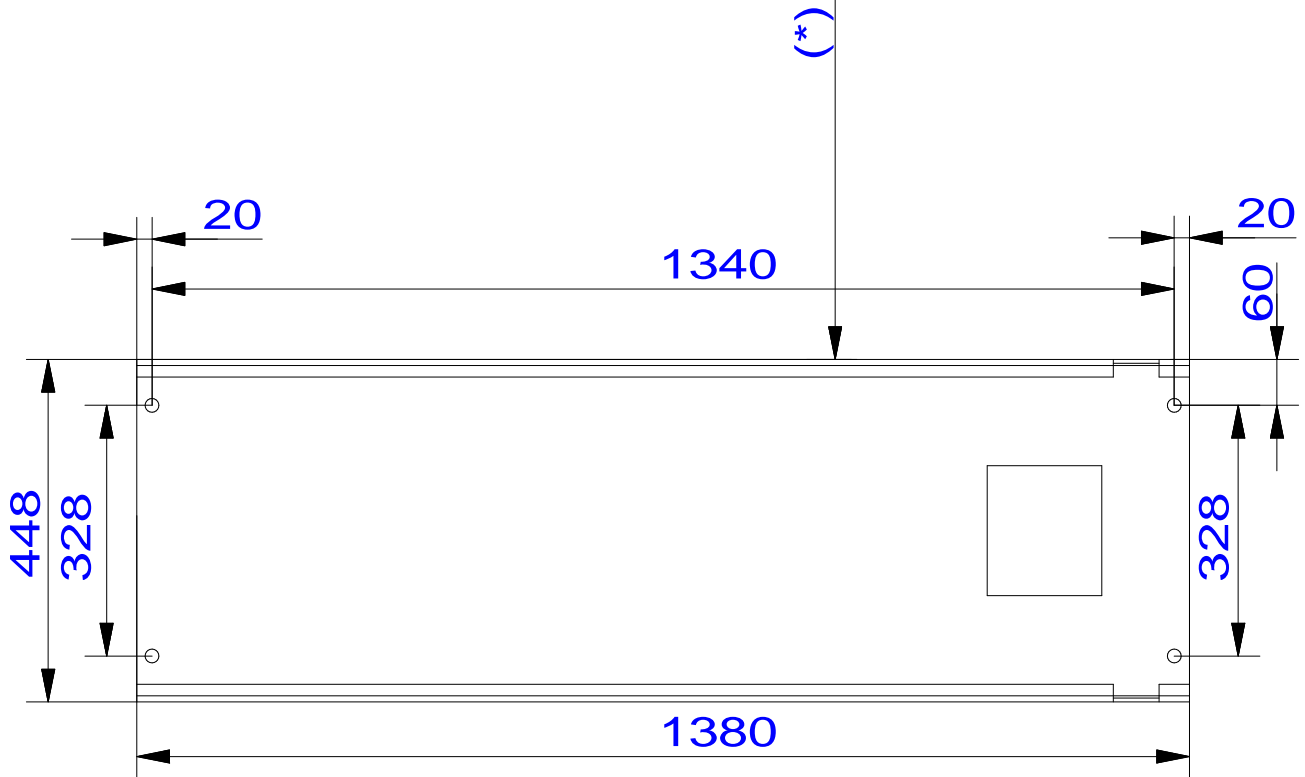

\* Standard = 902mm  
 BMW Maß = 1002mm



Alle Maße in mm! / all dimensions in mm!  
 Mass- und Konstruktionsänderungen vorbehalten! dimensions and design changes reserved!

030SPB05005 (3D CAD-Modell)				 Projektionsmethode 1 ISO 5456-2		Benennung / designation	
-	-	-	-	Datum	Name	<h1>Sprinter 3500 NT HF</h1> <p>Duebelbohrbild</p>	
-	-	-	-	Bearb. 02.11.2021	MH		
-	-	-	-	Gepr.			
-	-	-	-			Zeichnungsnummer / drawing number	
a	3000 kg auf 3500 kg	04.07.25	MH			Hertzstr. 6, 77694 Kehl www.nussbaumlifts.com	
ind.	Aender. / modification	Datum	Name				